

Surround Expander



MSE1

McIntosh

Thank You

Your decision to own this McIntosh MSE1 Surround Expander ranks you at the very top among discriminating music listeners. You now have “The Best.” The McIntosh dedication to “Quality,” is assurance that you will receive many years of musical enjoyment from this unit.

Please take a short time to read the information in this manual. We want you to be as familiar as possible with all the features and functions of your new McIntosh.

Please Take A Moment

The serial number, purchase date and McIntosh dealer name are important to you for possible insurance claim or future service. The spaces below have been provided for you to record that information:

Serial Number: _____

Purchase Date: _____

Dealer Name: _____

Technical Assistance

If at any time you have questions about your McIntosh product, contact your McIntosh dealer who is familiar with your McIntosh equipment and any other brands that may be part of your system. If you or your dealer wish additional help concerning a suspected problem, you can receive technical assistance for all McIntosh products at:

McIntosh Laboratory, Inc.
2 Chambers Street
Binghamton, New York 13903
Phone: 607-723-3512
Fax: 607-723-3636

Customer Service

If it is determined that your McIntosh product is in need of repair, you can return it to your dealer. You can also return it to the McIntosh Laboratory Service Repair Department. For assistance on factory repair return procedure, contact the McIntosh Repair Department at:

McIntosh Laboratory, Inc.
2 Chambers Street
Binghamton, New York 13903
Phone: 607-723-3515
Fax: 607-723-1917

Table of Contents

Thank You	2
Please Take a Moment	2
Technical Assistance	2
Customer Service	2
Table of Contents	2
Safety Instructions	3
Introduction	4
Performance Features	4
Dimensions	5
Installation	6
Rear Panel Switches and Connections	7
How to Connect with a MX132	8
How to Connect with a C39/MX130 and MSD4 or MAC3	10
How to Connect with a MSD4 or MAC-3	12
Front Panel Controls, Displays, Push-Buttons, and Switch	14
Speaker Settings	15
Surround Calibrations	16
How to Operate	19
Specifications	22
Packing Instruction	23

General Notes

- The following Connecting Cable is available from the McIntosh Parts Department:
Data and Power Control Cable Part No. 170-202
Six foot, shielded 2 conductor, with 1/8 inch stereo mini phone plugs on each end.*
- For additional connection information, refer to the owner's manual(s) for any component(s) connected to the MSE1 Surround Expander.*

IMPORTANT SAFETY INSTRUCTIONS!

PLEASE READ THEM BEFORE OPERATING THIS EQUIPMENT.



WARNING SHOCK HAZARD - DO NOT OPEN.

The lightning flash with arrowhead, within an equilateral triangle, is intended to alert the user to the presence of uninsulated "dangerous voltage" within the product's enclosure that may be of sufficient magnitude to constitute a risk of electric shock to persons.



AVIS RISQUE DE CHOC - NE PAS OUVRIR.

The exclamation point within an equilateral triangle is intended to alert the user to the presence of important operating and maintenance (servicing) instructions in the literature accompanying the appliance.

CAUTION
RISK OF ELECTRIC SHOCK
DO NOT OPEN

ATTENTION
DANGER D'ELECTROCUTION
NE PAS OUVRIR

NO USER-SERVICEABLE PARTS INSIDE. REFER SERVICING TO QUALIFIED PERSONNEL.

To prevent the risk of electric shock, do not remove cover (or back). No user serviceable parts inside. Refer servicing to qualified personnel.

General:

1. Read all the safety and operating instructions, contained in this owner's manual, before operating this equipment.
2. Retain this owner's manual for future reference about safety and operating instructions.
3. Adhere to all warnings and operating instructions.
4. Follow all operating and use instructions.
5. **Warning: To reduce risk of fire or electrical shock, do not expose this equipment to rain or moisture. This unit is capable of producing high sound pressure levels. Continued exposure to high sound pressure levels can cause permanent hearing impairment or loss. User caution is advised and ear protection is recommended when playing at high volumes.**
6. **Caution: to prevent electrical shock do not use this (polarized) plug with an extension cord, receptacle**

or other outlet unless the blades can be fully inserted to prevent blade exposure.

Attention: pour prevenir les chocs electriques pas utiliser cette fiche polarisee avec un prolongateur, une prise de courant ou un autre sortie de courant, sauf si les lames peuvent etre inserees afond ans en laisser aucune partie a decouvert.

7. For added protection for this product during a lightning storm, or when it is left unattended and unused for long periods of time, unplug it from the wall outlet. This will prevent damage to the product due to lightning or power line surges.
8. Do not use attachments not recommended in this owner's manual as they may cause hazards.

Installation:

9. Locate the equipment for proper ventilation. For example, the equipment should not be placed on a bed, sofa, rug, or similar surface that may block ventilation openings; or, placed in a built-in installation, such as a bookcase or cabinet, that may impede the flow of air through the ventilation openings.
10. Locate the equipment away from heat sources such as radiators, heat registers, stoves, or other appliance(s) (including amplifiers) that produce heat.
11. Mount the equipment in a wall or cabinet only as described in this owner's manual.
12. Do not use this equipment near water; for example, near a bathtub, washbowl, kitchen sink, laundry tub, in a wet basement or near a swimming pool, etc.
13. Do not place this product on an unstable cart, stand, tripod, bracket, or table. The equipment may fall, causing serious injury to a person, and serious damage to the product.

Connection:

14. Connect this equipment only to the type of AC power source as marked on the unit.
15. Route AC power cords so that they are not likely to be walked on or pinched by items placed upon or against them, paying particular attention to cords at plugs, convenience receptacles, and the point where they exit from the instrument.
16. Do not defeat the inherent design features of the polarized plug. Non-polarized line cord adapters will defeat the safety provided by the polarized AC plug. If the plug should fail to fit, contact your electrician to replace your obsolete outlet. Do not defeat the safety purpose of the grounding-type plug.

17. Do not overload wall outlets, extension cords or integral convenience receptacles as this can result in a risk of fire or electric shock.

Care of Equipment:

18. Clean the instrument by dusting with a dry cloth. Unplug this equipment from the wall outlet and clean the panel with a cloth moistened with a window cleaner. Do not use liquid cleaners or aerosol cleaners.
19. Do not permit objects or liquids of any kind to be pushed, spilled and/or fall into the equipment through enclosure openings.
20. Unplug the power cord from the AC power outlet when left unused for a long period of time.

Repair of Equipment:

21. Unplug this equipment from the wall outlet and refer servicing to a qualified service personnel under the following conditions:
 - A. The AC power cord or the plug has been damaged.
 - B. Objects have fallen, or liquid has been spilled into the equipment.
 - C. The equipment has been exposed to rain or water.
 - D. The equipment does not operate normally by following the operating instructions contained within this owner's manual. Adjust only those controls that are covered by the operating instructions, as an improper adjustment of other controls may result in damage and will often require extensive work by a qualified technician to restore the product to its normal operation.
 - E. The equipment has been dropped or damaged in any way.
 - F. The equipment exhibits a distinct change in performance - this indicates a need for service.
22. Do not attempt to service beyond that described in the operating instructions. All other service should be referred to qualified service personnel.
23. When replacement parts are required, be sure the service technician has used replacement parts specified by McIntosh or have the same characteristics as the original part. Unauthorized substitutions may result in fire, electric shock, or other hazards.
24. Upon completion of any service or repairs to this product, ask the service technician to perform safety checks to determine that the product is in proper operating condition.

Introduction

The McIntosh MSE1 is a precision Surround Expander which will reproduce the back channels of specially encoded 5.1 digital sound tracks with ultimate fidelity and sonic purity. The MSE1 has many valuable and useful features that will enhance your home theater listening experience.

Performance Features

● 24 Bit DSP Processing

The Motorola 24 Bit Digital Signal Processors decode the back channel information from specially encoded Digital 5.1 sound tracks.

● 20 Bit Conversion

Two 20 bit stereo digital to analog, (D/A) converters are used to reproduce the back channel information, and one 20 bit stereo analog to digital, (A/D) converter is for input signal from the analog inputs.

● Automatic Expansion Mode

The MSE1 automatically switches expansion modes when receiving specially encoded Digital 5.1 sound tracks (requires connections to the McIntosh MX132 A/V Control Center). Expand nomenclature illuminates to show which decoding mode is in use.

● LED Output Format / Delay / Volume Indicators

The MSE1 includes four LED's on the Front Panel to indicate status of the output signal format. In addition, there is a two digit LED indicator that shows the Trim Volume, Time Delay and Channel Level during surround level calibration.

● Adjustable Channel Time Delays

Signals to the back Surround channels can be time delayed. This feature can be used to correct the different listening distances from the back surround speaker(s) and the primary listening location.

● Built-In System Level Calibration Generator

A built-in test signal generator can be switched manually or automatically through all surround channels for surround level calibration. The levels can be adjusted plus or minus 6dB.

● Automatic Input Level Control

The Analog Input includes a special circuit which protects against accidental input signal overdrive.

Dimensions

The following dimensions can assist in determining the best location for your MSE1. There is additional information on the next page pertaining to installing the MSE1 into cabinets.

Front View of the MSE1



Rear View of the MSE1



Side View of the MSE1

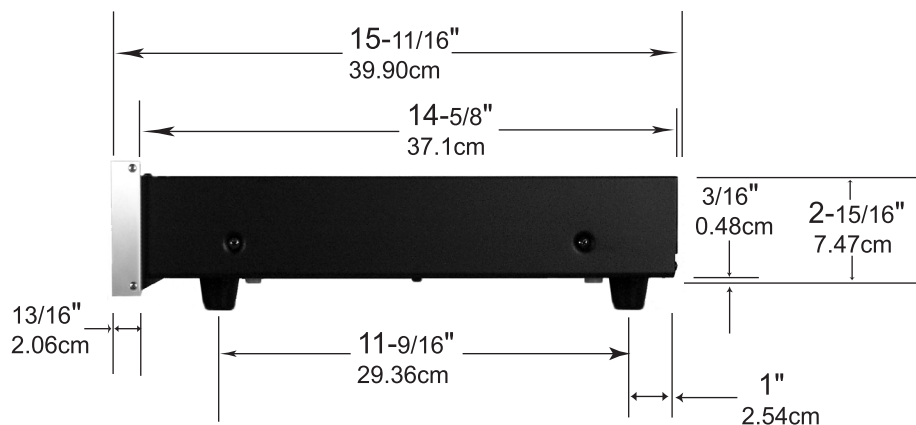

Installation

The MSE1 can be placed upright on a table or shelf, standing on its four feet. It also can be custom installed in a piece of furniture or cabinet of your choice. The required panel cutout, ventilation cutout and unit dimensions are shown.

Always provide adequate ventilation for your MSE1. Cool operation ensures the longest possible operating life for any electronic instrument. Do not install the MSE1 directly above a heat generating component such as a high powered amplifier. If all the components are installed in a single cabinet, a quiet running ventilation fan can be a definite asset in maintaining all the system components at the coolest possible operating temperature.

A custom cabinet installation should provide the following minimum spacing dimensions for cool operation. Allow at least 2 inches (5.08 cm) above the top, 2 inches (5.08cm) below the bottom and 1 inch (2.54 cm) on each side of the Surround Expander, so that airflow is not obstructed. Allow 20 inches (50.8 cm) depth behind the front panel. Allow 1 inch (2.54 cm) in front of the mounting panel for clearance. Be sure to cut out a ventilation hole in the mounting shelf according to the dimensions in the drawing.

MSE1 Front Panel Custom Cabinet Cutout

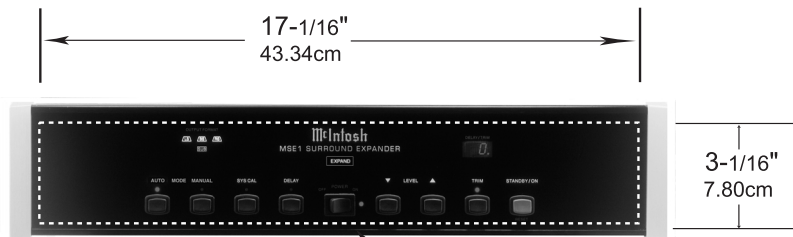

MSE1 Side View in Custom Cabinet

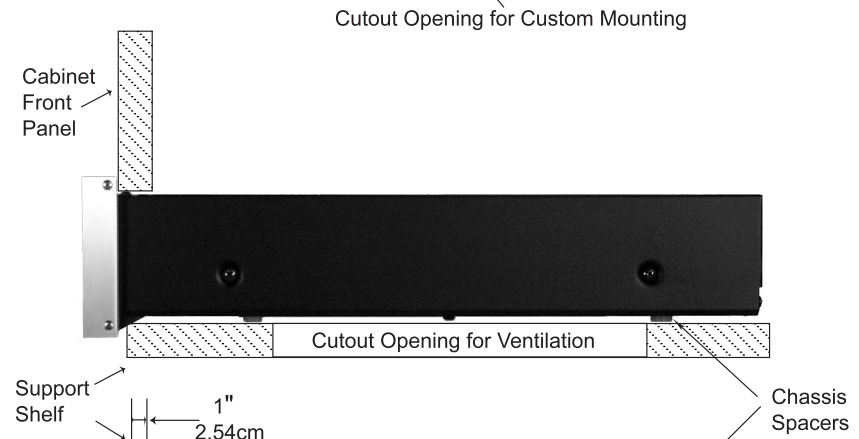

MSE1 Bottom View in Custom Cabinet

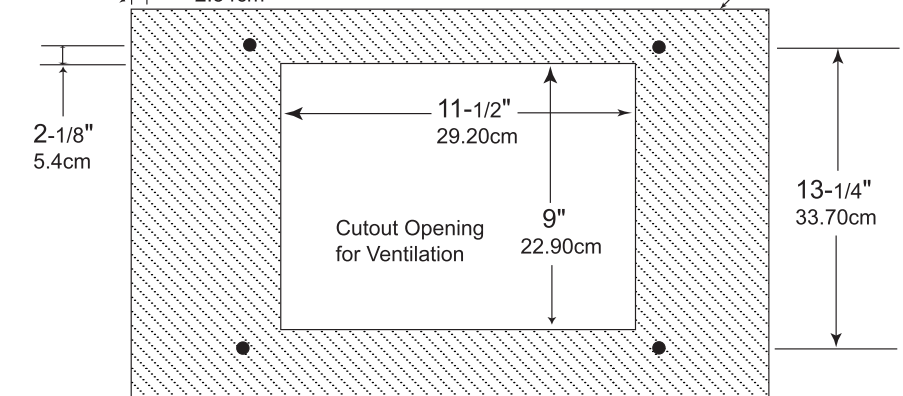

Connect the MSE1 power cord to a live AC outlet. Refer to information on the back panel of the MSE1 to determine the correct voltage

BACK1 OUTPUT provides the audio output signal to the power amplifier input for the Back Surround Loudspeaker

ANALOG INPUT receives Left and Right Surround Signals from the McIntosh A/V Control Center

SPEAKER SETTINGS switches allow the selection of one or two Back Surround Loudspeakers, their frequency response capability and whether or not an optional Secondary Subwoofer is used in the system

POWER CONTROL IN jack accepts a turn-on signal from a McIntosh Control Center. The POWER CONTROL OUT jack sends the turn-on signal to another McIntosh product

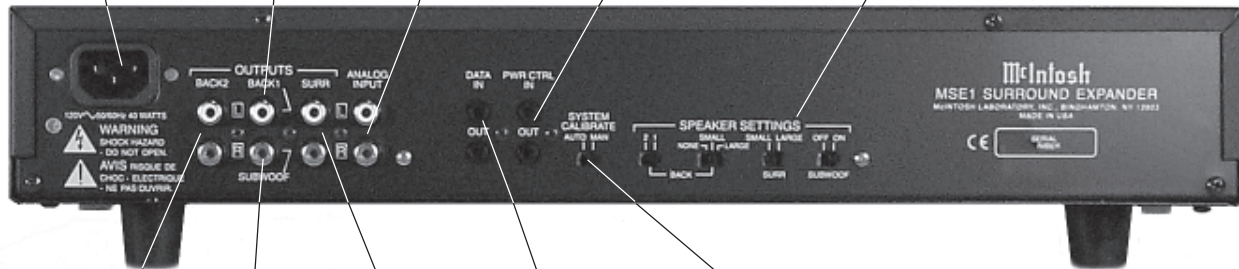

BACK2 OUTPUTS provide the audio output signals to the power amplifier inputs for the Left and Right Back Surround Loudspeakers

SURROUND Outputs provide the Left and Right Surround Signals to the power amplifier driving the Surround Loudspeakers

AUTOMATIC switches the built-in calibration test signal to each of the Surround Loudspeakers in 2 second intervals on a continuous basis. MANUAL system calibration requires the manual selection of Surround Loudspeakers

The SUBWOOFER OUTPUTS feed an audio signal to the input on a power amplifier for the optional secondary Subwoofer

DATA IN jack receives control data from a McIntosh A/V Control Center and the DATA OUT jack provides the control data for the next McIntosh Component

How to Connect with a MX132

The following connection instructions and illustrations cover the addition of the McIntosh MSE1 Surround Expander, McIntosh Back Surround Power Amplifier and optional secondary McIntosh Power Subwoofer into an existing MX132 Home Theater System. For additional connection information, please refer to the owner's manuals for the particular components that make up your system.

1. Connect a Power Control Cable from the MX132 Power Control A jack to the POWER CONTROL IN jack of the McIntosh MSE1 Surround Expander.
2. Connect a Power Control Cable from the POWER CONTROL OUT jack of the McIntosh MSE1 Surround Expander to the Power Control In jack of the McIntosh Back Surround Power Amplifier.
3. Connect a Power Control Cable from the Power Control Out jack of the McIntosh Five Channel Power Amplifier to the Power Control In jack of the McIntosh Powered Subwoofer.
4. Connect a Data cable from the MX132 Sum A Data Out Port to the DATA IN of a jack of the McIntosh MSE1 Surround Expander.
5. Connect cables from the MX132 Zone A Surround Outputs to the ANALOG Inputs of the McIntosh MSE1 Surround Expander.
6. Temporarily disconnect the male end of the 25 conductor DB25 cable from the McIntosh Five Channel Power Amplifier. Locate and remove (cut out) pins 5, 6, 18 and 19 from the male connector end of the DB25 cable. Reconnect the now modified male end of the DB25 cable to the McIntosh Five Channel Power Amplifier.

Note: The above step is necessary, as the Left and Right Surround Channels receive additional sound processing in the MSE1 Surround Expander. The next step connects the MSE1 Surround Outputs to the McIntosh Five Channel Power Amplifier using the audio connection cables. If your system consists of a McIntosh Six Channel Power Amplifier the same above step must also be performed.

7. Connect cables from the McIntosh MSE1 Surround Expander SURROUND Outputs to the Surround Inputs of the McIntosh Five Channel Power Amplifier.
8. Connect cables from the McIntosh MSE1 Surround Expander BACK2 Outputs to the Inputs of the McIntosh Surround Power Amplifier.

Note: The MSE1 also has a BACK1 Output that provides a single Surround Back Channel that may be used in place of the BACK2 Output.

9. Connect the loudspeaker hookup cables to the output terminals of the McIntosh Surround Power Amplifier.
10. Plug the MSE1 AC power cord into a live AC outlet.

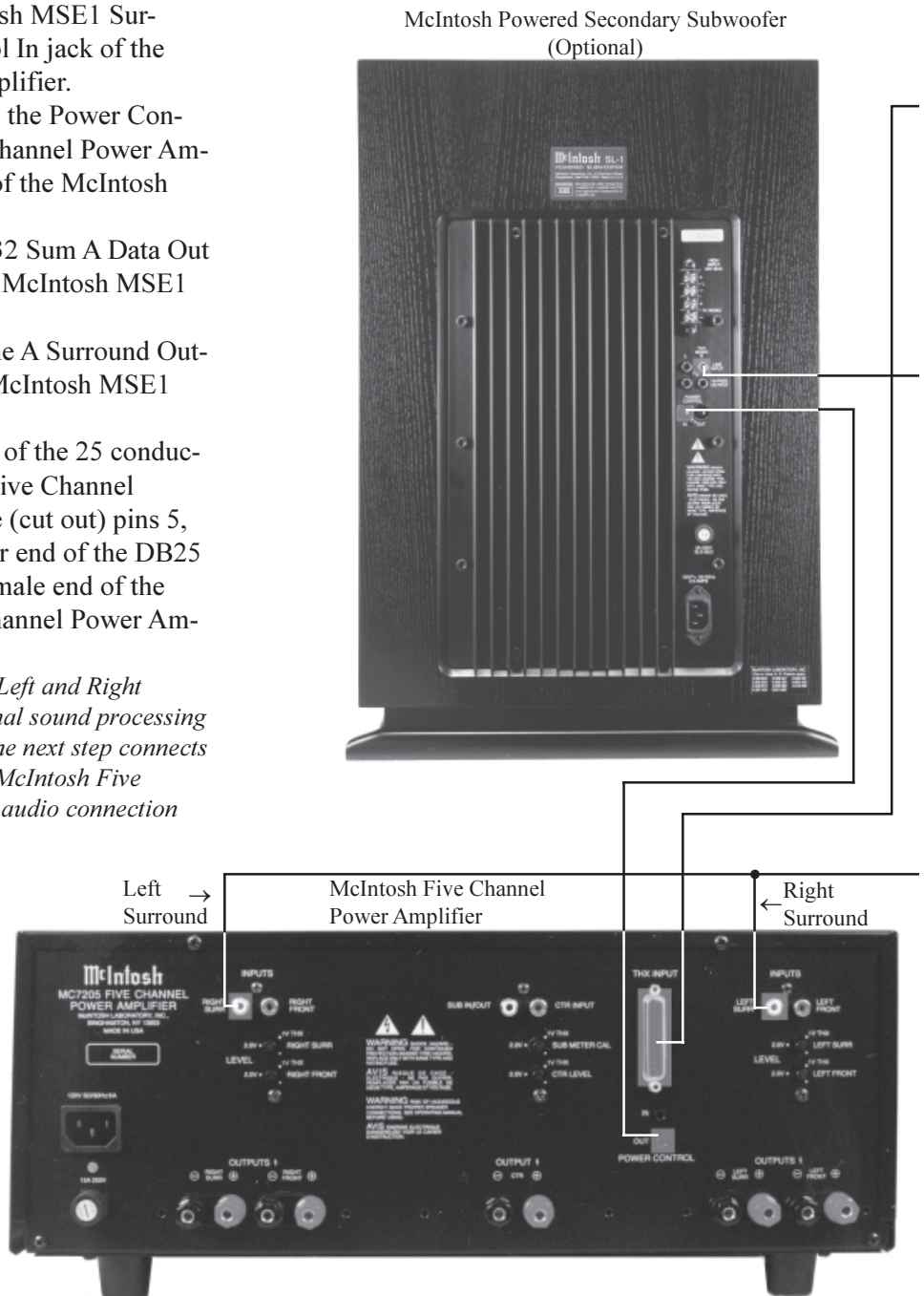

McIntosh MX132

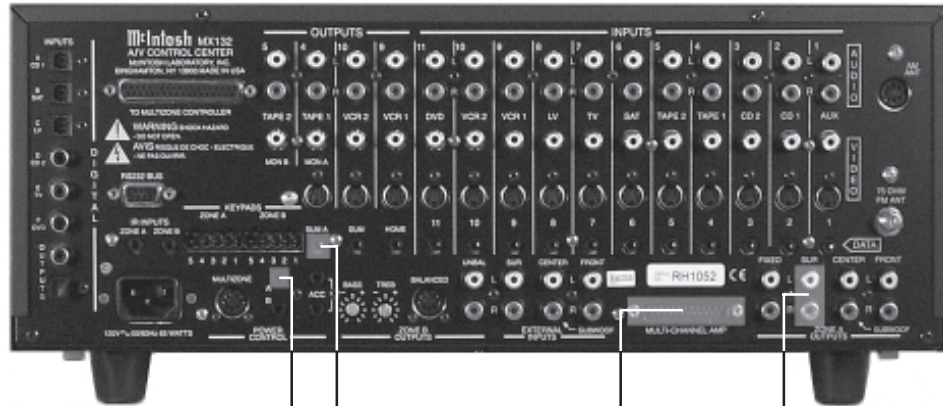

Refer to step 6 and note on previous page ↓

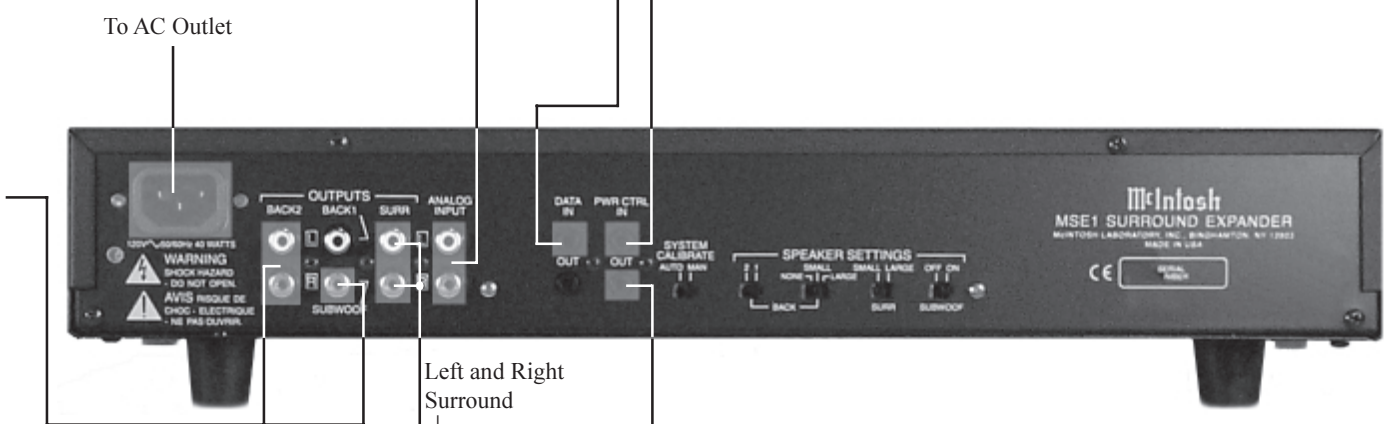

To AC Outlet

Left and Right Surround

McIntosh Back Surround Power Amplifier

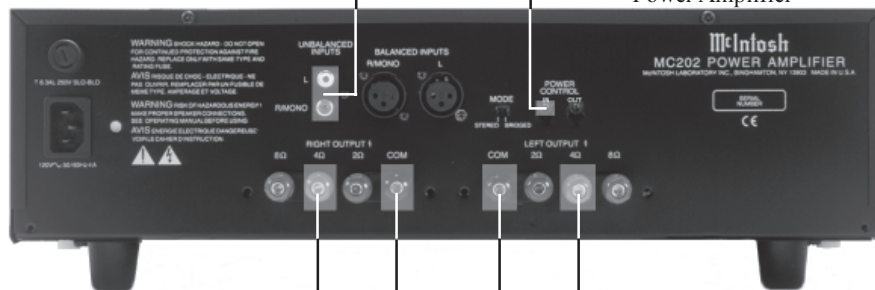

Right Back Surround Loudspeaker 4 ohm

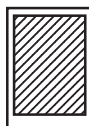

Left Back Surround Loudspeaker 4 ohm



How to Connect with a MX130/C39 and MSD4/MAC-3

The following connection instructions and illustrations cover the addition of the McIntosh MSE1 Surround Expander, Back Surround Power Amplifier and optional secondary Power Subwoofer into an existing McIntosh Home Theater System. For additional connection information, please refer to the owner's manuals for the particular components that make up your system.

1. Connect a Power Control Cable from the MX130/C39 Power Control (Area A) jack to the Power Control In jack of the MSD4/MAC-3.
2. Connect a Power Control Cable from the MSD4/MAC-3 Power Control Out to the POWER CONTROL IN jack of the McIntosh MSE1.
3. Connect a Power Control Cable from the POWER CONTROL OUT jack of the McIntosh MSE1 Surround Expander to the Power Control In jack of the Back Surround Power Amplifier.
4. Connect a Power Control Cable from the Power Control Out jack of the five channel power amplifier to the Power Control In jack of the Powered Subwoofer.
5. Connect a Data cable from the MX130/C39 Sum Data (Area A) Out Port to the Data In jack of the MSD4/MAC-3.
6. Connect a Data cable from the MSD4/MAC-3 Data Out Port to the DATA IN jack of the McIntosh MSE1 Surround Expander.
7. Connect cables from the MX130 Area A Surround Outputs to the ANALOG Inputs of the McIntosh MSE1 Surround Expander.
8. Temporarily disconnect the male end of the 25 conductor DB25 cable from the McIntosh Five Channel Power Amplifier. Locate and remove (cut out) pins 5, 6, 18 and 19 from the male connector end of the DB25 cable. Reconnect the now modified male end of the DB25 cable to the five channel power amplifier.

Note: The above step is necessary, as the Left and Right Surround Channels receive additional sound processing in the MSE1 Surround Expander. The next step connects the MSE1 Surround Outputs to the five channel power amplifier using the audio connection cables. If your system consists of a six channel power amplifier the same above step must also be performed.

9. Connect cables from the McIntosh MSE1 Surround Expander

SURround Outputs to the Surround Inputs of the five channel power amplifier.

10. Connect cables from the McIntosh MSE1 Surround Expander BACK2 Outputs to the Inputs of the surround power amplifier.

Note: The MSE1 also has a BACK1 Output that provides a single Surround Back Channel that may be used in place of the BACK2 Output.

11. Connect the loudspeaker hookup cables to the output terminals of the surround power amplifier.
12. Plug the MSE1 AC power cord into a live AC outlet.

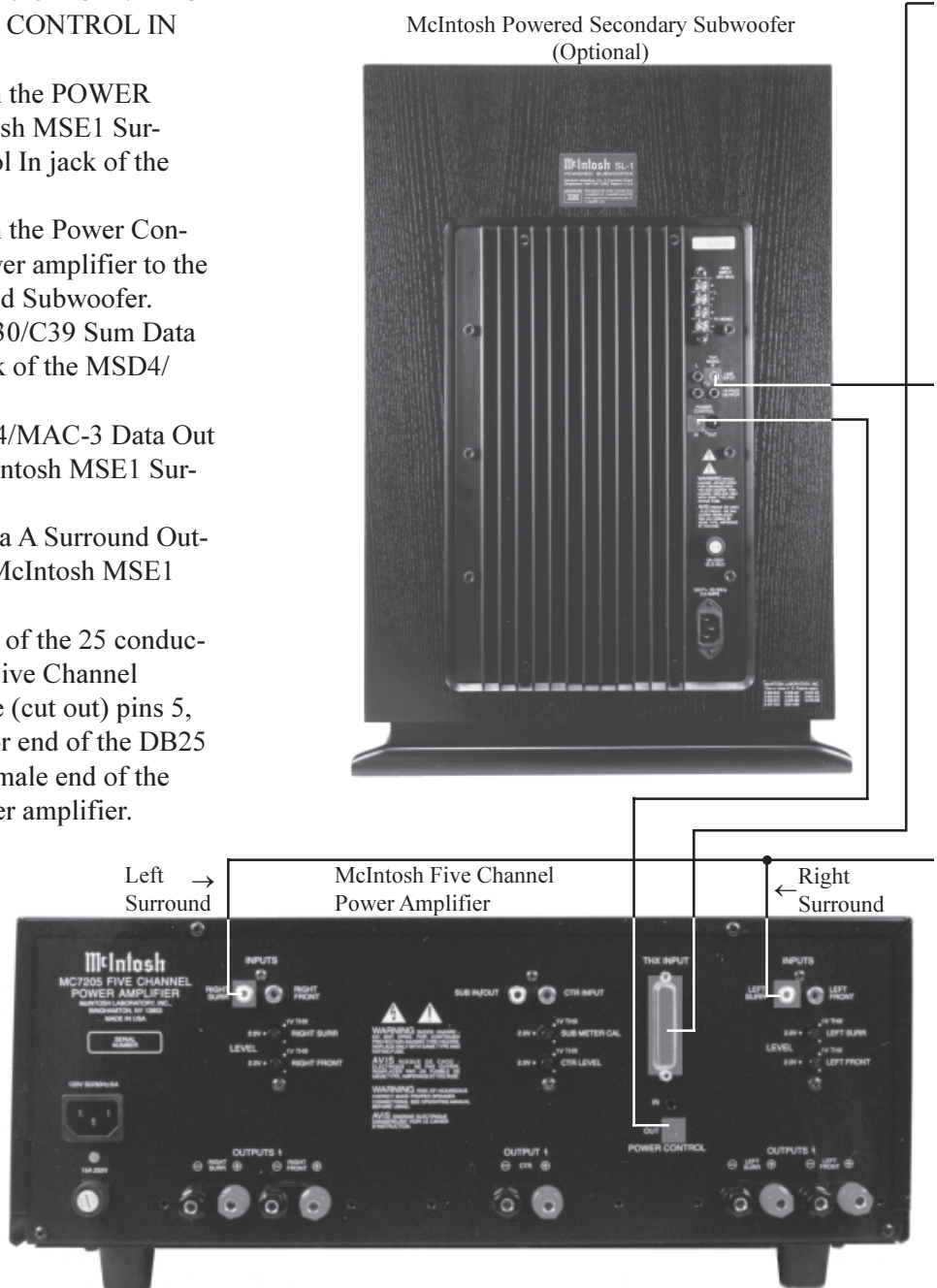

How to Connect with a MX130/C39 and MSD4/MAC-3

McIntosh MX130/C39



McIntosh MSD4/MAC-3

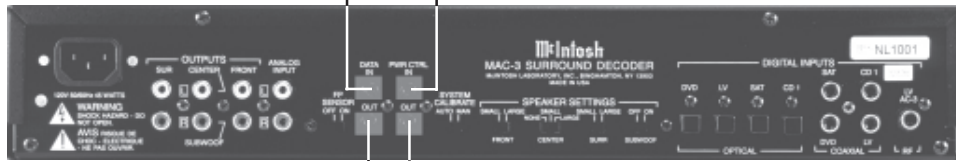

Refer to step 8 and note on previous page ↓

To AC Outlet

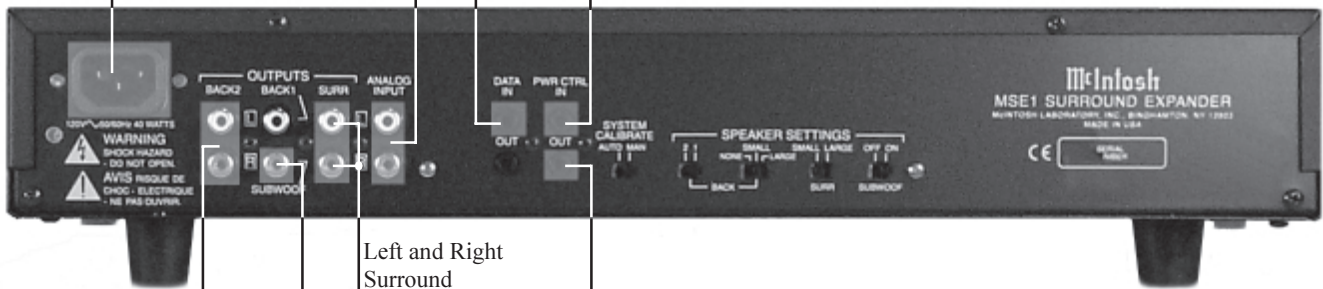

Left and Right Surround

McIntosh Back Surround Power Amplifier

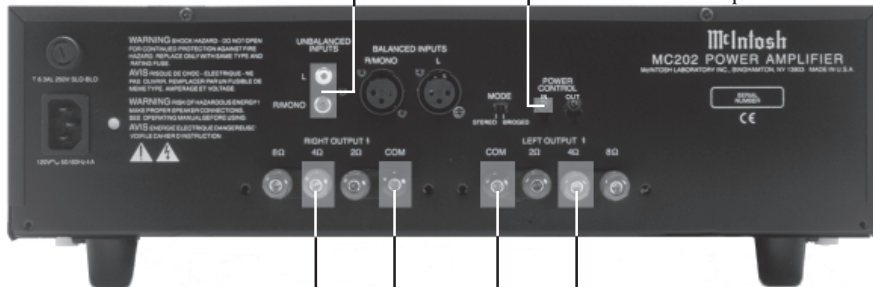

Right Back Surround Loudspeaker
4 ohm

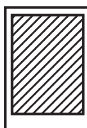

Left Back Surround Loudspeaker
4 ohm



How to Connect with a MSD4/MAC-3

The following connection instructions and illustrations cover the addition of the McIntosh MSE1 Surround Expander, Back Surround Power Amplifier and optional secondary Power Subwoofer into an existing MSD4/MAC-3 Home Theater System. For additional connection information, please refer to the owner's manuals for the particular components that make up your system.

1. Connect a Power Control Cable from the MSD4/MAC-3 Power Control Out jack to the POWER CONTROL IN jack of the McIntosh MSE1 Surround Expander.
2. Connect a Power Control Cable from the POWER CONTROL OUT jack of the McIntosh MSE1 Surround Expander to the Power Control In jack of the back surround power amplifier.
3. Connect a Power Control Cable from the Power Control Out jack of the back surround power amplifier to the Power Control In jack of the five channel power amplifier.

Note: A six channel power amplifier may also be used in place of the five channel amplifier.

4. Connect a Power Control Cable from the Power Control Out jack of the five channel power amplifier to the Power Control In jack of the powered subwoofer.
5. Connect a Data cable from the MSD4/MAC-3 Data Out Port to the DATA IN of a jack of the McIntosh MSE1 Surround Expander.
6. Connect cables from the MSD4/MAC-3 Surround Outputs to the ANALOG INPUTS of the McIntosh MSE1 Surround Expander.
8. Connect cables from the McIntosh MSE1 Surround Expander SURROUND Outputs to the Surround Inputs of the five channel power amplifier.
9. Connect cables from the McIntosh MSE1 Surround Expander BACK2 Outputs to the Inputs of the surround power amplifier.

Note: The MSE1 also has a BACK1 Output that provides a single Surround Back Channel that may be used in place of the BACK2 Output.

10. Connect the loudspeaker hookup cables to the output terminals of the surround power amplifier.
11. Plug the MSE1 AC power cord into a live AC outlet.

McIntosh Powered Secondary Subwoofer (Optional)

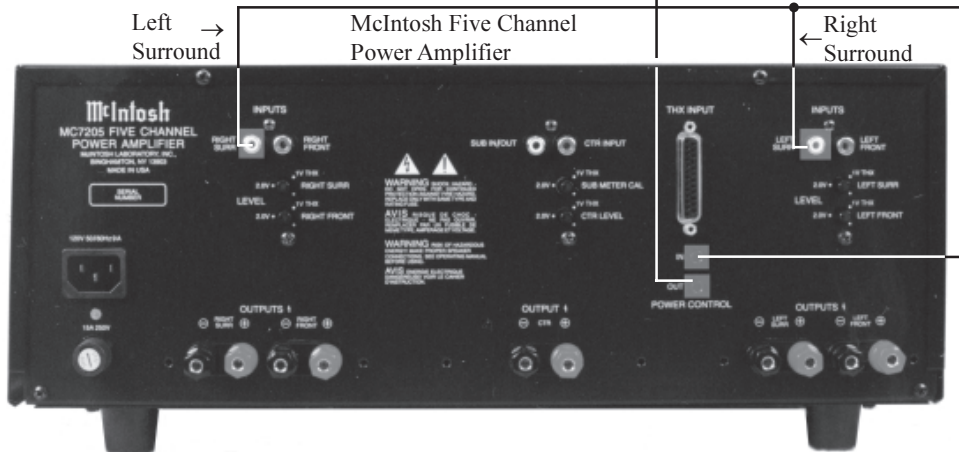

McIntosh MSD4/MAC-3

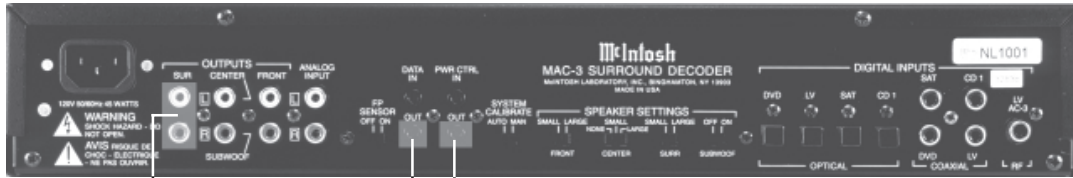

To AC Outlet

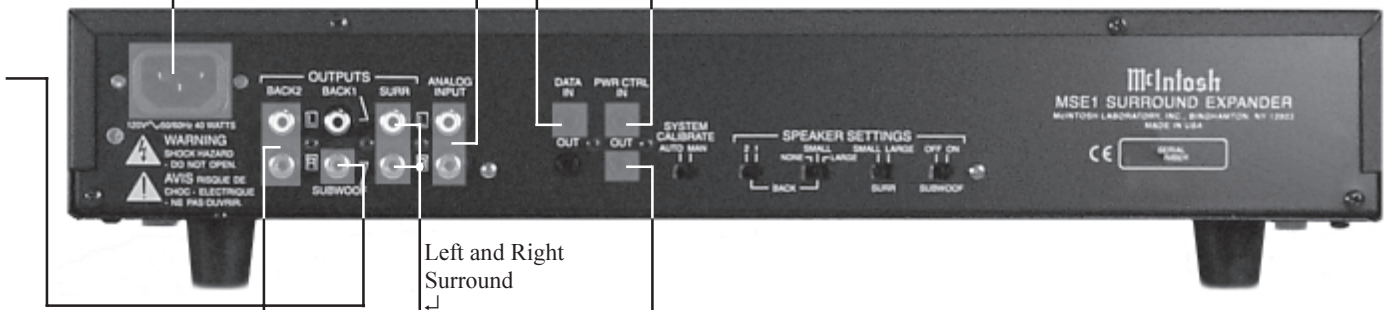

Left and Right Surround

McIntosh Back Surround Power Amplifier

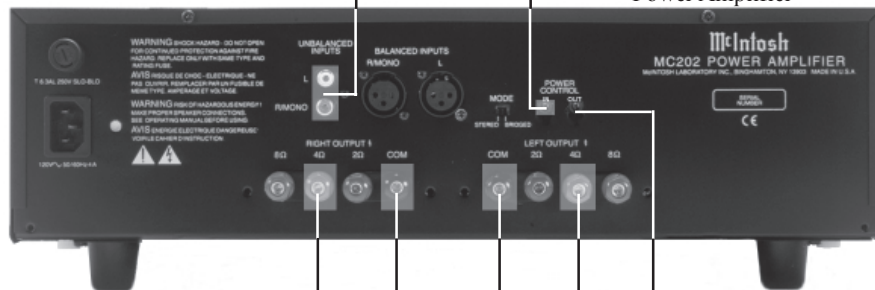

Right Back Surround Loudspeaker 4 ohm

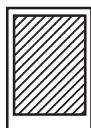

Left Back Surround Loudspeaker 4 ohm



AUTO MODE allows for automatic switching and indicating of the Surround Expansion Mode

DELAY push-button activates the Time Delay Adjusting Process for the Back Surround Loudspeaker(s)

DELAY/TRIM Indicator shows the Trim Volume Level, Channel Level and Time Delay

CHANNEL STATUS LED display indicates which channels are active, depending on the incoming signal; LS (Left Surround), BS (Back Surround), RS (Right Surround) and SUB (Subwoofer)

Indicates when the MSE1 is in the Surround EXPAND Mode

STANDBY/ON push-button turns the MSE1 on and off, and can reset all the MSE1 microprocessors



MANUAL MODE allows for manual switching of the Surround Expansion Mode

POWER switch turns all power completely ON or OFF

LEVEL ▼ and ▲ push-buttons allow for volume adjustment of all the Surround Loudspeakers

SYS CAL push-button activates the internal test signal generator for surround channel level calibration

Indicates when AC Power is applied to the MSE1

TRIM push-button activates the Volume Level Push-buttons for all the Surround Channels

Speaker Settings

The McIntosh MSE1 Rear Panel Speaker Settings are for selecting the number of Back Surround Loudspeaker(s), the size of all the Surround Loudspeakers and if an optional secondary Subwoofer is used. Refer to figures 1, 2 and 3.

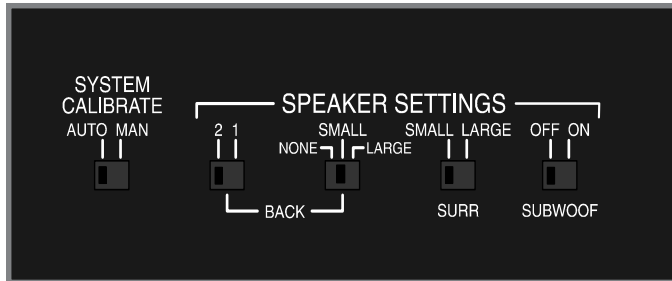

Figure 1

Back 1 and 2 Selection

The MSE1 Surround Expander may be operated with either a single Center Back Surround Loudspeaker or a Left and Right Back Surround Loudspeakers. Select the either the BACK 1 or 2 Switch Position to match your system.

Note: If your system is using a Left and Right Back Surround Loudspeakers the actual signal sent to them is the same and is reduced in level by 3dB over a single Center Back Surround Loudspeaker Setup.

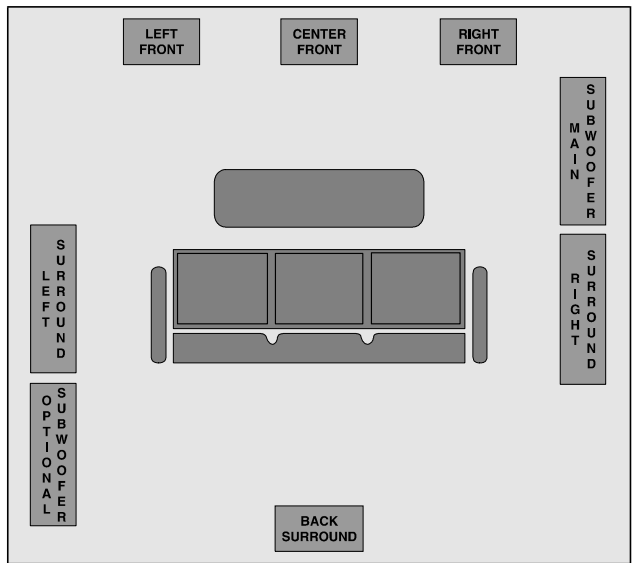

Figure 3

Surround Speaker Size

When the Left and Right Surround Loudspeakers cover the full frequency range down to 20Hz, set the switch to LARGE. If the Left and Right Surround Loudspeakers cover the frequency range only down to 80Hz, set the switch to SMALL.

Subwoofer Speaker

Set the SUBWOOF switch to ON whenever the Optional Secondary Subwoofer is used in the system. In this mode, the Low Frequencies are sent to the subwoofer when either the Left and Right Surround or the Back Surround Loudspeaker SPEAKER Switches are set to SMALL. If both Side and Back Surround Loudspeakers SPEAKER Switch setting is LARGE, all the low frequencies will be redirected to the Surround Loudspeakers and no sound will be heard from the Subwoofer.

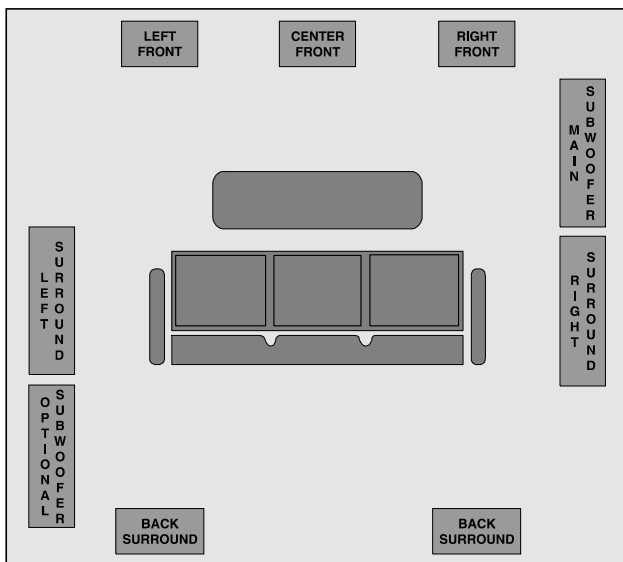

Figure 2

Back Surround Speaker Size

When the Back Surround Loudspeaker(s) cover the full frequency range down to 20Hz, set the switch to LARGE. If the Back Surround Loudspeakers cover the frequency range only down to 80Hz, set the switch to SMALL. The NONE Speaker Switch position should be selected when no Back Surround Loudspeakers are connected or when the Surround Expansion Processing is bypassed.

Surround Calibration

The McIntosh MSE1 Surround Expander provides automatic expansion of “Surround Enhancement Information” contained in movie sound tracks. This additional information is encoded in the surround channels by using a Matrix Method. The MSE1 converts the incoming analog surround channels into digital signals, processes the signals digitally, then convert it back to analog signals consisting of the Left Surround, Right Surround and Back Surround Channels.

In order to assure the best possible Surround Expansion, it is extremely important that both Surround Channel Signals going into the MSE1 have as close as possible the same level and time delay characteristics. Adjust the levels and delay settings for the surround channels of your Home Theater System for the same surround channel loudspeaker level and the time delay settings, refer to the Owners Manual supplied with McIntosh A/V Control Center and/or Surround Decoder. If there are differences in the settings between the surround channels, then pick the average between the two surround channels settings and use that average for both Surround Channels.

Delay and Level calibration procedures are made relative to the primary listening area. The ideal listening area is defined as facing directly toward and centered between the front speakers, in line with the left and right surround speakers and the back surround louspeaker(s) behind the primary listening area. Refer to the figures 4 and 5.

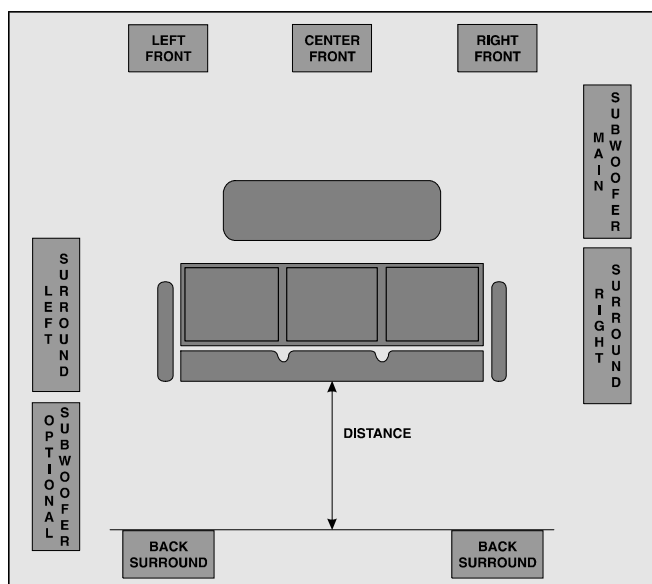

Figure 4

Back Surround Speaker Delay

If the back surround speakers are located closer to the listening area than the surround speakers, their sound will reach the listener before the sound from the surround

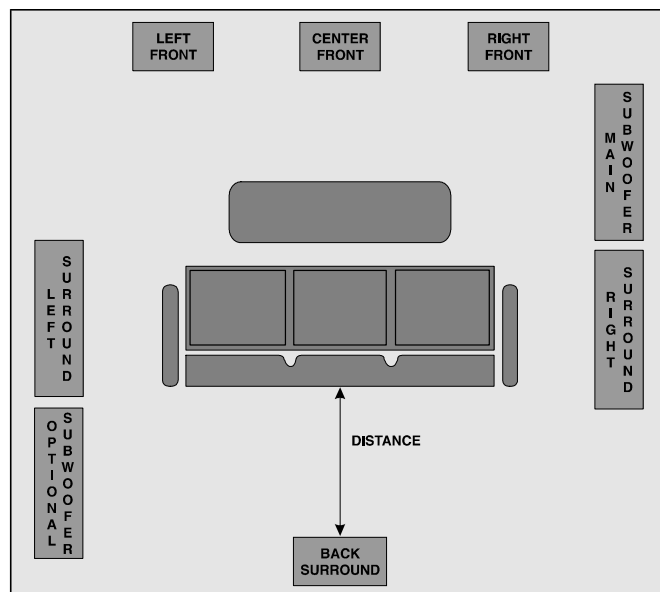

Figure 5

speakers. This difference in sound arrival times can degrade the listening perception of some sound tracks. The MSE1 allows you to adjust the back surround speaker time delay to correct for this difference so the sound from the back surround speakers reaches the listening area at the same time as sound from the left and right surround loudspeakers. Refer to figure 6.

Note: The MSE1 surround delay can be adjusted from 0 to 5ms. Each millisecond delay corresponds approximately to 1 foot in distance.

The first time you press the DELAY push-button the DELAY/TRIM display will indicate 0, which the factory default setting. This would correspond to the delay setting you have just performed on your McIntosh A/V Control Center and/or Surround Decoder for the Left and Right Surround Loudspeakers.

1. Measure the distance from the listening area to the Back Surround Loudspeaker(s). If the Back Surround Loudspeakers are closer than the average distance from the listening area to the Left and Right Surround Loudspeakers you should adjust the delay to correspond to the difference in feet.
2. Press the DELAY push-button to start delay calibration procedure.
3. Adjust the LEVEL ▲ and ▼ push-buttons until the DELAY/TRIM display reads a number that is the same as the number of feet measured in Step 1.

Note: The table on the next page may be used to record your Delay Calibration Settings.

4. Press the DELAY push-button a second time to exit the delay procedure.

Example: If your Back Surround Loudspeaker(s) are 2 feet closer to the listening area than the Left and Right Surround Loudspeakers, set the center delay to “2”.

Surround Delay Calibration		
Surround Channel	Default Setting	New Setting
Left		
Right		
Back		

Surround Speaker Levels

The MSE1 includes a built-in test signal generator to perform System Level Calibration. A properly calibrated Surround Sound System should have all channel levels adjusted for similar volume in the listening area. This ensures that multi-channel sound tracks will be reproduced with optimum realism. Individual channel levels from an actual sound track usually change widely on a continuous basis. Proper System Calibration sets all channels to the correct starting reference level. Refer to figure 6.

Note: All System Level Calibrations are retained in permanent memory and will change only if calibration is performed again. A sound level pressure meter may be used to obtain a more accurate Level Calibration.

Automatic System Calibration

1. Set the rear panel SYSTEM CALIBRATION switch to AUTO.
2. Press the SYS CAL push-button once to start System Calibration. You will hear the test signal from the Left Surround Loudspeaker for 2 seconds. The test signal will then cycle clockwise through all Surround Channels and optional Secondary Subwoofer continuously in 2 second intervals. The MSE1 DELAY/TRIM display will read “0” for each channel before any adjustments are performed.

Note: The MSE1 Front Panel DELAY/TRIM Display will read “0” for each channel before any adjustments are

performed and the OUTPUT FORMAT LED’s will light to indicate which channel is reproducing the test signal.

3. While seated in the listening area, note the volume levels of the test signal from each of the channels as the test signal switches. If you determine that the test signal volume is louder or softer in any of the channels, the levels should be adjusted so you hear essentially the same test signal volume from all of the channels. The Left Surround Loudspeaker can serve as a reference.
 4. Make channel level calibration adjustments by using the LEVEL ▲ and ▼ push-buttons, the DELAY/VOLUME display instantly changes to indicate the calibration level change in dB. If the level is increased, the display shows plus numbers, and if decreased shows minus numbers. Calibration levels can be adjusted over a range of ±6dB. If an adjustment is made on a channel, there is an additional 2 second time interval on that channel before the system switches the test signal to the next channel.
 5. When the test signal switches to succeeding channels, repeat the level calibration process until the test signal volume levels of all the channels are the same.
 6. The calibration channel cycling mode can be repeated as often as necessary until you are satisfied that the volume levels of the test signal are the same from all channels.
- Note: A Surround Level Calibration Table, located on the next page, is provided to record your settings.*
7. Exit the System Calibration mode by pressing the SYS CAL push-button a second time.

Manual System Calibration

1. Set the rear panel SYSTEM CALIBRATE switch to MAN.
2. Press the SYS CAL push-button once to start System Calibration, you will hear the test signal from the Left Surround Loudspeaker. It will stay in that channel until the SYS CAL push-button is pressed again. The second time SYS CAL push-button is pressed the sound will



Figure 6

switch to the Back Surround Loudspeaker(s) followed by the Left Surround and Subwoofer. The MSE1 DELAY/TRIM display will read "0" for each channel before any adjustments are performed.

Note: The MSE1 Front Panel DELAY/TRIM Display will read "0" for each channel before any adjustments are performed and the OUTPUT FORMAT LED's will light to indicate which channel is reproducing the test signal.

3. While seated in the listening area, note the volume levels of the test signal from each of the channels as the test signal switches. If you determine that the test signal volume is louder or softer in any of the channels, the levels should be adjusted so you hear essentially the same test signal volume from all of the channels. The Left Surround Loudspeaker can serve as a reference.
4. Make channel level calibration adjustments by using the LEVEL ▲ and ▼ push-buttons, the DELAY/VOLUME display instantly changes to indicate the calibration level change in dB. If the level is increased, the display shows plus numbers, and if decreased shows minus numbers. Calibration levels can be adjusted over a range of ±6dB. If an adjustment is made on a channel, there is an additional 2 second time interval on that channel before the system switches the test signal to the next channel.
5. When the test signal switches to succeeding channels, repeat the level calibration process until the test signal volume levels of all the channels are the same.
6. The calibration channel cycling mode can be repeated as often as necessary until you are satisfied that the volume levels of the test signal are the same from all channels.

Note: A Surround Level Calibration Table to the right is provided to record your settings.

7. Exit the System Calibration mode by pressing the SYS CAL push-button a second time.

Surround Level Calibration		
Surround Channel	Default Setting	New Setting
Left		
Right		
Back Left		
Back Right		
Back Center		
Secondary Subwoofer		



Figure 6

How to Operate the MSE1

Power On

Press the POWER Switch to ON. The Red LED, to the right of the POWER Switch, lights to indicate the MSE1 is in Standby Mode. To turn ON the MSE1 press the STANDBY/ON push-button. Refer to figure 7.

Note: The POWER Switch is only intended to be switched OFF when the MSE1 Surround Expander is not used for extended periods of time, like while away on vacation. During normal operation, the POWER Switch should stay in the ON position. Press the STANDBY/ON Push-button for turning the MSE1 ON and OFF. When the Power Control Cable is connected to a McIntosh A/V Control Center or Surround Decoder, the MSE1 Surround Expander will automatically switch ON and OFF.



Figure 7

Reset of Microprocessors

In the event that the controls of the MSE1 stop functioning, there is a user reset function built in. While the MSE1 is On, press and hold in the STANDBY/ON/RESET push-button for five seconds, this will reset the MSE1's microprocessors. In rare circumstances the pushing of the STANDBY/ON/RESET push-button for five seconds might not reset the MSE1's microprocessors. If that were to occur, then place the POWER Switch to the OFF position for two to five minutes and then back ON again.

Note: The above condition is usually caused by either interruptions in AC power and/or major changes in voltage.

Auto Mode

Pressing the AUTO MODE push-button places the MSE1 in the Automatic Surround Expansion Mode of operation and the LED above the push-button lights. When the MSE1 receives, via its data port, the correct control signal the MSE1 will automatically switch into the Surround Expansion Mode and the Back Surround Loudspeaker(s) will reproduce the added sound track information. If there is no control signal present, the Surround Expansion Mode will switch Off and no sound will be heard from the Back Surround Loudspeaker(s). Refer to figure 8.

Note: Currently only the MX132 has the ability to pass on that control signal to the MSE1. The MX132 continuously monitors the digital signal bitstream from its rear panel optical or coaxial digital inputs. The expander will only be engaged when specially encoded 5.1 sound tracks are recognized by the MX132. If the bitstream changes, the MSE1 processor is notified of the change, which lights the EXPAND indicator and the appropriate OUTPUT FORMAT LED's.

Manual Mode

Pressing the MANUAL MODE push-button places the MSE1 in the Surround Expansion Mode of operation and the LED above the push-button lights. The MSE1 will continuously operate in the Surround Expansion Mode and provide surround expansion from any 5.1 or Pro-Logic sound track material that are reproduced with decorrelated surround channels. The MSE1 lights the EXPAND indicator and the appropriate OUTPUT FORMAT LED's. Refer to figure 8.

Sys Cal

A built-in test signal generator can be switched manually or automatically through all surround channels for level calibration. The levels can be adjusted ± 6 dB. The MSE1 has a super precision volume trim control, and its tracking accuracy for all four channels is within one quarter of a dB throughout its range. Refer to figure 6.



Figure 8

Delay

The Back Surround channel has an adjustable time delay. This compensates for speakers that are placed at varying distances, and insures that sound from all speakers arrive at the listening position at the same time. The delay time is adjustable from 0mS to 5mS in 1ms steps, which is a distance approximately zero to 5 feet. Refer to figure 8.

Level ▲ and ▼

The push-buttons allow the up and down adjustment of Back Surround Channel Delay, the Surround Channels and Subwoofer Levels during the calibration process. They also allow all the Surround Loudspeaker Levels to change while listening. Refer to figure 8.

Note: The TRIM push-button needs to be pressed first, to activate the LEVEL push-buttons.

Trim

Pressing the TRIM push-button allows the MSE1 Surround Loudspeakers Levels to go up and down $\pm 6\text{dB}$, when used with the LEVEL ▲ and ▼ push-buttons. The LED above the TRIM push-button lights to indicate that the Trim function is active. Refer to figure 8.



Figure 8

Specifications

Frequency Response

Surround Loudspeakers (Large Speaker Setting)
+ 0, -0.5dB from 20Hz to 20,000Hz

Surround Loudspeakers (Small Speaker Setting)
+ 0, -0.5dB from 80Hz to 20,000Hz

Subwoofer Loudspeaker
+ 0, -0.5dB from 20Hz to 80Hz

Rated Output

2.0V

Output Impedance

Less than 100ohms

Maximum Output Voltage

6.0V

Total Harmonic Distortion

0.005% at all outputs

Sensitivity

200mV

Signal To Noise Ratio

Greater than 90dB (A-weighted)
Greater than 98dB CCIR

Maximum Input Signal

3.5V

Voltage Gain

Unity gain from Input to Output
(±6dB adjustment with TRIM LEVEL)

Power Requirements

100 Volts, 50/60Hz at 40 watts
110 Volts, 50/60Hz at 40 watts
120 Volts, 50/60Hz at 40 watts
220 Volts, 50/60Hz at 40 watts
230 Volts, 50/60Hz at 40 watts
240 Volts, 50/60Hz at 40 watts

NOTE: Refer to the rear panel of the MSE1 for the correct voltage.

Dimensions

17-1/2" (44.5cm) W, 3-9/16" (9.0cm) H, 15-11/16"
(39.90cm) D, (including clearance for connectors)

Weight

19.5 pounds (8.85 Kg) net, 35.5 pounds (16.1 Kg) in shipping carton

Packing Instructions

In the event it is necessary to repack the equipment for shipment, the equipment must be packed exactly as shown below. It is very important that the four plastic feet are attached to the bottom of the equipment. This will ensure the proper equipment location on the bottom pad. Failure to do this will result in shipping damage.

Use the original shipping carton and interior parts only if they are all in good serviceable condition. If a shipping carton or any of the interior part(s) are needed, please call or write Customer Service Repair Department of McIntosh Laboratory. Please see the Parts List for the correct part numbers.

Quantity	Part Number	Description
1	033770	Shipping carton only
4	034022	Foam end cap
1	033606	Inside carton only
1	033726	Top pad
1	033729	Bottom pad
1	033622	Inner carton pad
4	017218	Plastic foot
4	100159	#10-32 x 3/4" screw
4	104083	#10 x 7/16" Flat washer
1	048095	Shipping carton complete with all the above parts

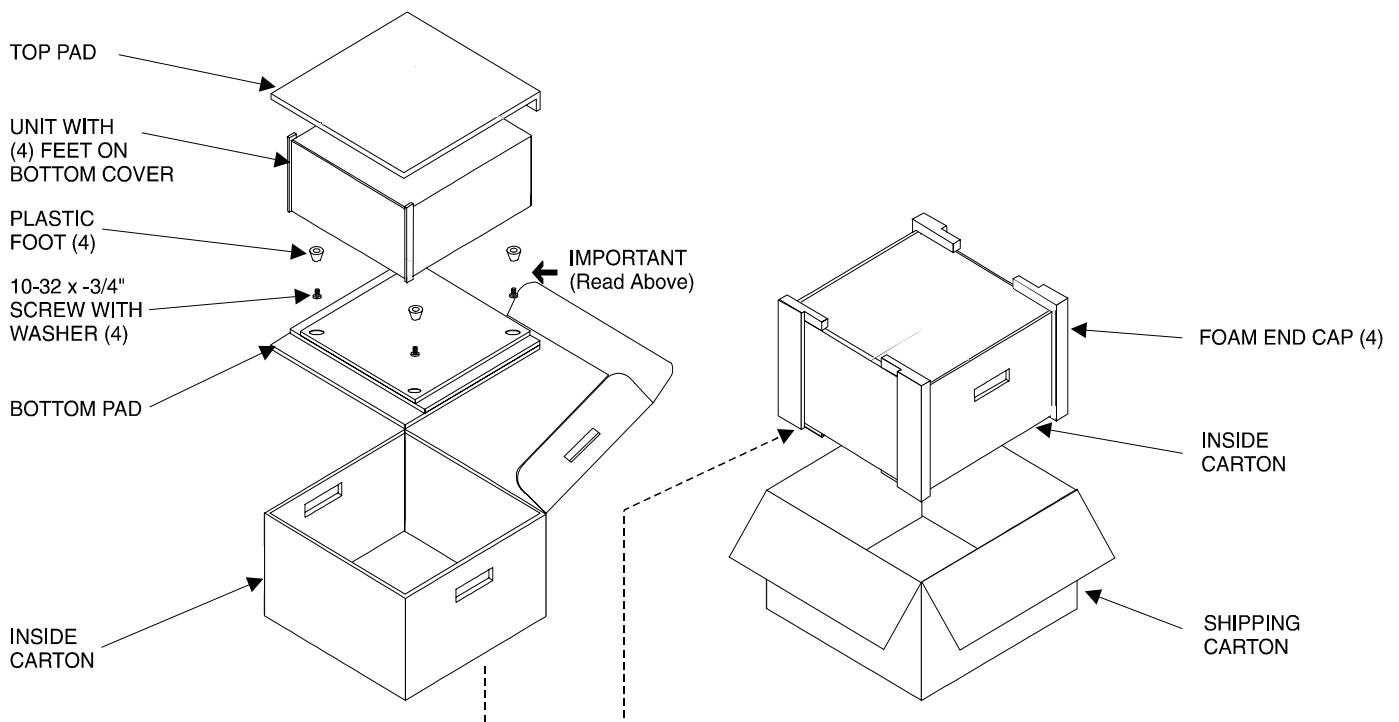

McIntosh[®]

McIntosh Laboratory, Inc.
2 Chambers Street
Binghamton, NY 13903

McIntosh Part No. 040720